

Fan Maintenance Checklist

Fan ID _____ Date _____

Customer

Company _____

Address _____

Contact _____

Phone _____

Fax _____

Email _____

PO; Workorder _____

Purpose _____

Service Personnel

Company _____

Address _____

Contact _____

Phone _____

Fax _____

Email _____

Signature _____

Fan Data

Manufacturer _____ Model & Size _____

Fan Rpm _____ Rot & Disch _____

Fan Arrg _____ Motor Pos. _____

Fan Const _____

Age/History _____

Comments _____

Fan ID _____ Date _____

Motor Data

Motor Mfg _____ Type _____ SN _____

Motor HP _____ Frame _____ RPM _____

FLA _____ Act Amp _____ Act Voltage _____

Efficiency _____ Power Factor _____ Phase _____

Age/History _____

Comments _____

Drive Data

V Belt Centers _____ Belts _____

Tension _____ Design Tension _____

Coupling Type _____ Mfg _____ Size _____

Bearings Type _____ Size _____ Grease/Oil _____

Bearing Temp Inboard _____ Outboard _____

Age/History _____

Comments _____

Installation Data

Foundation _____

Isolation Rubber _____ Spring _____ Qty _____

Mounting Bolts Missing _____ Bolts Tight _____ Level _____

Flex Connector Inlet _____ Outlet _____ Type _____

Inlet Ducting _____ Size _____

Outlet Ducting _____ Size _____

Describe Mounting Structure _____

Airstream Temp _____ Material Conveyed, Rate _____

Comments _____

Fan ID _____

Date _____

Overall Velocity Vibration

Bearing Enveloped Acceleration

Positions	Vertical	Horizontal	Axial	10:00	12:00	2:00
Fan Inboard Bearing	Left	_____	_____	_____	_____	_____
	Right	_____	_____	_____	_____	_____
Fan Outboard Bearing	Left	_____	_____	_____	_____	_____
	Right	_____	_____	_____	_____	_____
Motor Inboard Foot	Left	_____	_____	_____	_____	_____
	Right	_____	_____	_____	_____	_____
Motor Outboard Foot	Left	_____	_____	_____	_____	_____
	Right	_____	_____	_____	_____	_____

- Overall velocity vibration measurements are used to evaluate rotational and structural problems such as imbalance, resonance, misalignment, looseness, soft foundation, bent shaft and stress. Units are inches/second or mils (mm/second); Range is 10 to 1 kHz.
- AMCA 204-96, BV-3 Limits:

Rigid Base <	Start Up, 0.25 in/sec	Alarm, 0.40 in/sec	Shut Down, 0.50 in/sec
Flexible Base <	Start Up, 0.35 in/sec	Alarm, 0.65 in/sec	Shut Down, 0.70 in/sec
- Bearing enveloped acceleration measurements represent the high frequency repetitive vibration signals typically caused by bearing and gear mesh problems that can be hidden by the lower frequency rotational or structural noise. Units are g forces (acceleration). Range is 10 to 30 kHz. Target, < 4 g.

Comments: _____

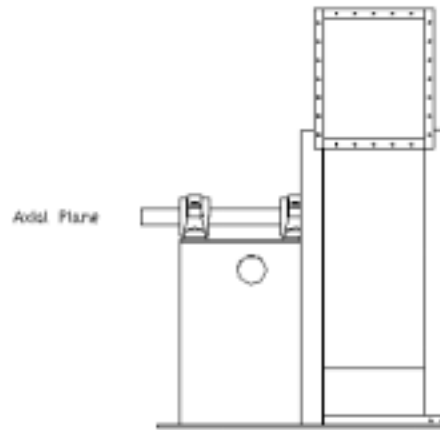
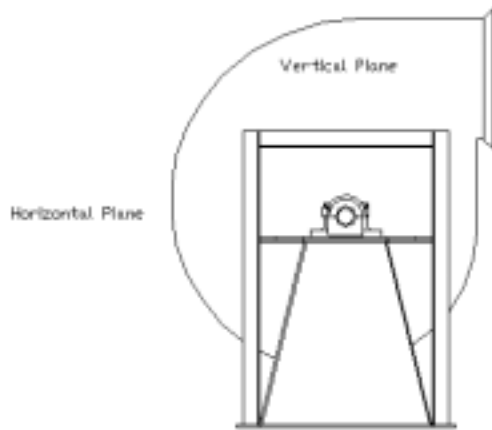
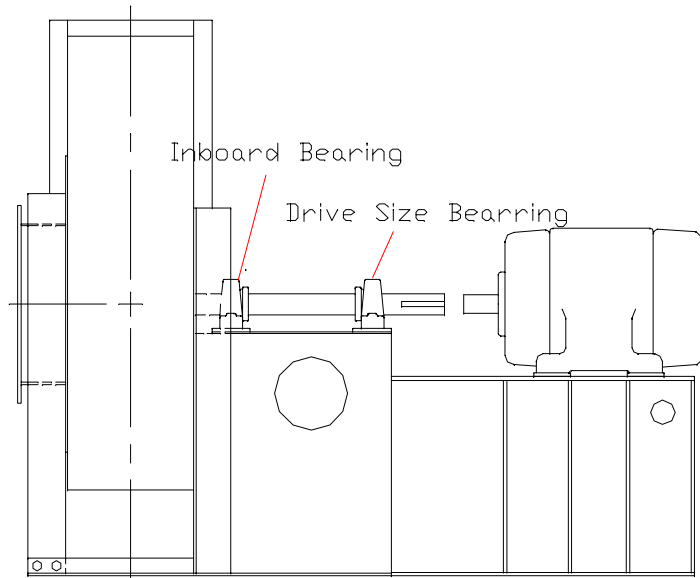

Vertical Plane

Horizontal Plane

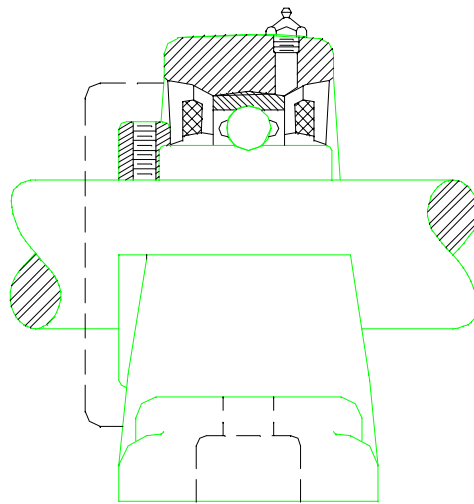
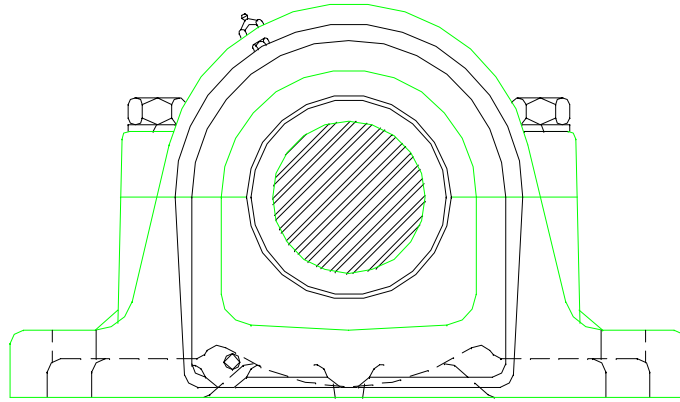

Axial Plane